

Turning toolholders internal

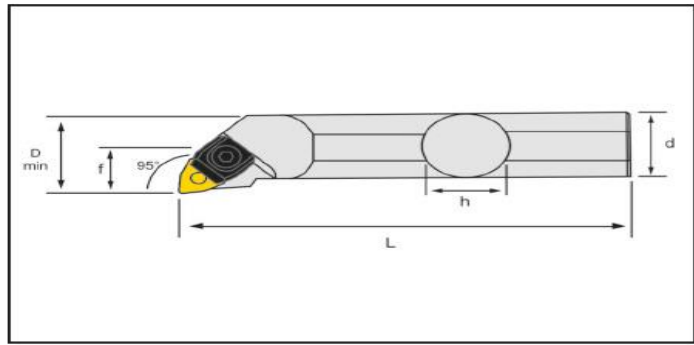
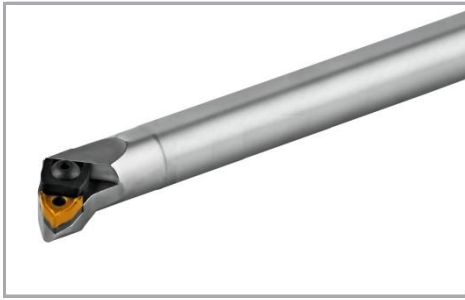

Unit mm

Application	Insert	Order code	Part code	Dimensions						Master insert
				dm	h	b	l1	f1	Dmin	
95°	06	I138.20.220.06.1	S20R MWLNR 06	20	18	18	220	13	25	WNMG 0604
		I138.25.250.06.1	S25S MWLNR 06	25	23	23	250	17	32	WNMG 0604
		I138.32.300.06.1	S32T MWLNR 06	32	30	30	300	22	40	WNMG 0604
	08	I138.25.250.08.1	S25S MWLNR 08	25	23	23	250	17	32	WNMG 0804
		I138.32.300.08.1	S32T MWLNR 08	32	30	30	300	22	40	WNMG 0804
		I138.40.350.08.1	S40U MWLNR 08	40	37	37	350	27	50	WNMG 0804
		I138.50.420.08.1	S50V MWLNR 08	50	47	47	420	35	63	WNMG 0804
95°	06	I138.20.220.06.2	S20R MWLNL 06	20	18	18	220	13	25	WNMG 0604
		I138.25.250.06.2	S25S MWLNL 06	25	23	23	250	17	32	WNMG 0604
		I138.32.300.06.2	S32T MWLNL 06	32	30	30	300	22	40	WNMG 0604
	08	I138.25.250.08.2	S25S MWLNL 08	25	23	23	250	17	32	WNMG 0804
		I138.32.300.08.2	S32T MWLNL 08	32	30	30	300	22	40	WNMG 0804
		I138.40.350.08.2	S40U MWLNL 08	40	37	37	350	27	50	WNMG 0804
		I138.50.420.08.2	S50V MWLNL 08	50	47	47	420	35	63	WNMG 0804

Spare parts, parts included in delivery

Designation	Clamp	Clamping screw	Wrench	Spring
..20	A110.101	A110.101 (M5)	A109.105(3 HK)	A113.101
..25	A110.101	A110.101 (M5)	A109.105(3 HK)	A113.101
..25	A110.102	A110.102 (M6)	A109.107(4 HK)	A113.102
..32	A110.101	A110.101 (M5)	A109.107(3 HK)	A113.101
..32	A110.102	A110.102 (M6)	A109.107(4 HK)	A113.102
..40	A110.101	A110.101 (M5)	A109.107(3 HK)	A113.101
..40	A110.102	A110.102 (M6)	A109.107(4 HK)	A113.102
..50	A110.102	A110.102 (M6)	A109.107(4 HK)	A113.102

Please check availability in current price and stock list