

Turning toolholders internal

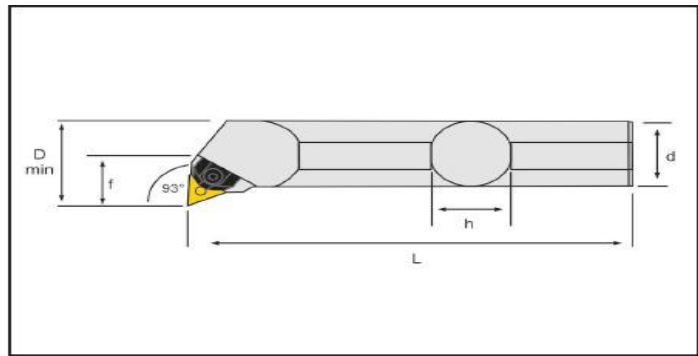

Unit mm

Application	Insert	Order code	Part code	Dimensions						Master insert
				dm	h	b	l1	f1	Dmin	
93°	16	I134.20.220.16.1	S20R MTUNR 16	20	18	18	220	13	25	TNMG 1604
		I134.25.250.16.1	S25S MTUNR 16	25	23	23	250	17	32	TNMG 1604
		I134.32.300.16.1	S32T MTUNR 16	32	30	30	300	22	40	TNMG 1604
		I134.40.350.16.1	S40U MTUNR 16	40	37	37	350	27	50	TNMG 1604
	22	I134.25.250.22.1	S25S MTUNR 22	25	23	23	250	17	32	TNMG 2204
		I134.32.300.16.1	S32T MTUNR 16	32	30	30	300	22	40	TNMG 2204
		I134.40.350.16.1	S40U MTUNR 16	40	37	37	350	27	50	TNMG 2204
		I134.50.420.22.1	S50V MTUNR 22	50	47	47	420	35	63	TNMG 2204
93°	16	I134.20.220.16.2	S20R MTUNL 16	20	18	18	220	13	25	TNMG 1604
		I134.25.250.16.2	S25S MTUNL 16	25	23	23	250	17	32	TNMG 1604
		I134.32.300.16.2	S32T MTUNL 16	32	30	30	300	22	40	TNMG 1604
		I134.40.350.16.2	S40U MTUNL 16	40	37	37	350	27	50	TNMG 1604
	22	I134.25.250.22.2	S25S MTUNL 22	25	23	23	250	17	32	TNMG 2204
		I134.32.300.16.2	S32T MTUNL 16	32	30	30	300	22	40	TNMG 2204
		I134.40.350.16.2	S40U MTUNL 16	40	37	37	350	27	50	TNMG 2204
		I134.50.420.22.2	S50V MTUNL 22	50	47	47	420	35	63	TNMG 2204

Spare parts, parts included in delivery

Designation	Clamp	Clamping screw	Wrench	Spring
..20	A110.103	A110.101 (M5)	A109.105(3 HK)	A113.101
..25	A110.103	A110.101 (M5)	A109.105(3 HK)	A113.101
..25	A110.104	A110.102 (M6)	A109.107(4 HK)	A113.102
..32	A110.103	A110.101 (M5)	A109.107(3 HK)	A113.101
..32	A110.104	A110.102 (M6)	A109.107(4 HK)	A113.102
..40	A110.103	A110.101 (M5)	A109.107(3 HK)	A113.101
..40	A110.104	A110.102 (M6)	A109.107(4 HK)	A113.102
..50	A110.104	A110.102 (M6)	A109.107(4 HK)	A113.102

Please check availability in current price and stock list