

# Turning toolholders internal

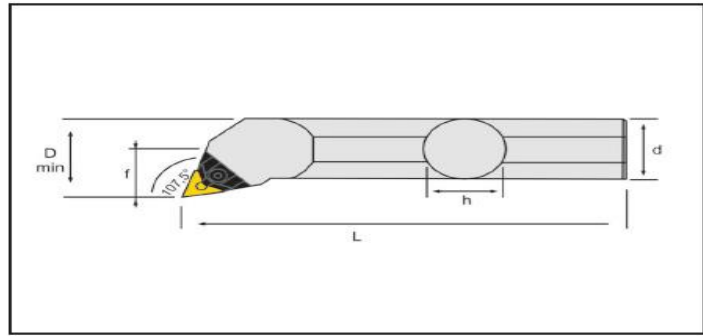

Unit mm

Application	Insert	Order code	Part code	Dimensions						Master insert
				dm	h	b	l1	f1	Dmin	
<b>107.5°</b>	<b>16</b>	<b>I136.20.220.16.1</b>	S20R MTQNR 16	20	18	18	220	13	25	TNMG 1604
		<b>I136.25.250.16.1</b>	S25S MTQNR 16	25	23	23	250	17	32	TNMG 1604
		<b>I136.32.300.16.1</b>	S32T MTQNR 16	32	30	30	300	22	40	TNMG 1604
		<b>I136.40.350.16.1</b>	S40U MTQNR 16	40	37	37	350	27	50	TNMG 1604
	<b>22</b>	<b>I136.25.250.22.1</b>	S25S MTQNR 22	25	23	23	250	17	32	TNMG 2204
		<b>I136.32.300.16.1</b>	S32T MTQNR 16	32	30	30	300	22	40	TNMG 2204
		<b>I136.40.350.16.1</b>	S40U MTQNR 16	40	37	37	350	27	50	TNMG 2204
		<b>I136.50.420.22.1</b>	S50V MTQNR 22	50	47	47	420	35	63	TNMG 2204
<b>107.5°</b>	<b>16</b>	<b>I136.20.220.16.2</b>	S20R MTQNL 16	20	18	18	220	13	25	TNMG 1604
		<b>I136.25.250.16.2</b>	S25S MTQNL 16	25	23	23	250	17	32	TNMG 1604
		<b>I136.32.300.16.2</b>	S32T MTQNL 16	32	30	30	300	22	40	TNMG 1604
		<b>I136.40.350.16.2</b>	S40U MTQNL 16	40	37	37	350	27	50	TNMG 1604
	<b>22</b>	<b>I136.25.250.22.2</b>	S25S MTQNL 22	25	23	23	250	17	32	TNMG 2204
		<b>I136.32.300.16.2</b>	S32T MTQNL 16	32	30	30	300	22	40	TNMG 2204
		<b>I136.40.350.16.2</b>	S40U MTQNL 16	40	37	37	350	27	50	TNMG 2204
		<b>I136.50.420.22.2</b>	S50V MTQNL 22	50	47	47	420	35	63	TNMG 2204

Spare parts, parts included in delivery

Designation	Clamp	Clamping screw	Wrench	Spring
..20	A110.103	A110.101 (M5)	A109.105(3 HK)	A113.101
..25	A110.103	A110.101 (M5)	A109.105(3 HK)	A113.101
..25	A110.104	A110.102 (M6)	A109.107(4 HK)	A113.102
..32	A110.103	A110.101 (M5)	A109.107(3 HK)	A113.101
..32	A110.104	A110.102 (M6)	A109.107(4 HK)	A113.102
..40	A110.103	A110.101 (M5)	A109.107(3 HK)	A113.101
..40	A110.104	A110.102 (M6)	A109.107(4 HK)	A113.102
..50	A110.104	A110.102 (M6)	A109.107(4 HK)	A113.102

Please check availability in current price and stock list