

Turning toolholders internal

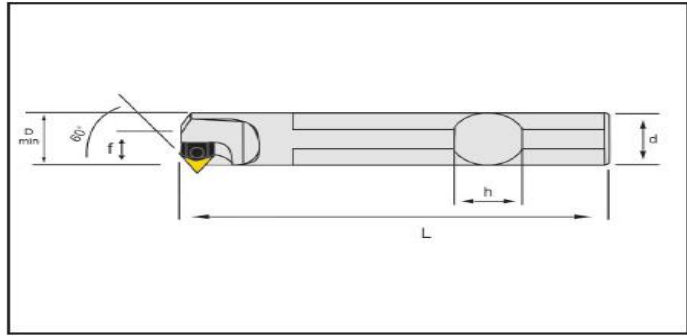
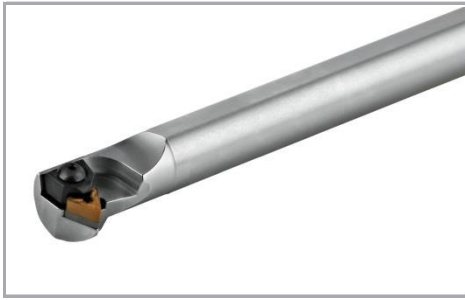

Unit mm

Application	Insert	Order code	Part code	Dimensions						Master insert
				dm	h	b	l1	f1	Dmin	
60°	16	I138.25.250.16.1	S25S MT-NR 16	25	23	23	250	17	32	TNMG 1604
		I138.32.300.16.1	S32T MT-NR 16	32	30	30	300	22	40	TNMG 1604
	22	I138.40.350.22.1	S40U MT-NR 22	40	37	37	350	27	50	TNMG 2204
		I138.50.420.22.1	S50V MT-NR 22	50	47	47	420	35	63	TNMG 2204
60°	16	I138.25.250.16.2	S25S MT-NL 16	25	23	23	250	17	32	TNMG 1604
		I138.32.300.16.2	S32T MT-NL 16	32	30	30	300	22	40	TNMG 1604
		I138.40.350.22.2	S40U MT-NL 22	40	37	37	350	27	50	TNMG 2204
	22	I138.50.420.22.2	S50V MT-NL 22	50	47	47	420	35	63	TNMG 2204

Spare parts, parts included in delivery

Designation	Clamp	Clamping screw	Wrench	Spring
..25	A110.103	A110.101 (M5)	A109.105(3 HK)	A113.101
..32	A110.103	A110.101 (M5)	A109.105(3 HK)	A113.101
..40	A110.104	A110.102 (M6)	A109.107(4 HK)	A113.102
..50	A110.104	A110.102 (M6)	A109.107(3 HK)	A113.102

Please check availability in current price and stock list