

Turning toolholders internal

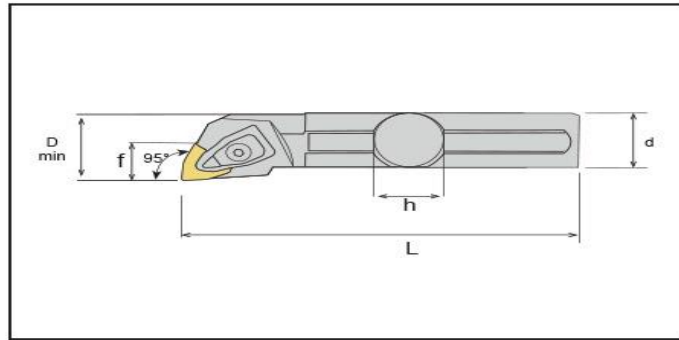
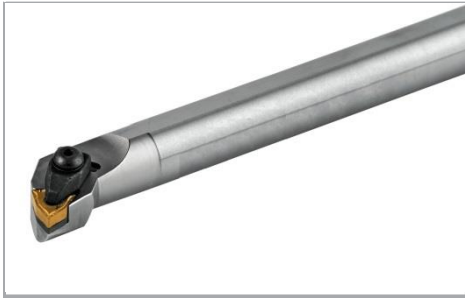

Unit mm

Application	Insert	Order code	Part code	Dimensions						Master insert
				dm	h	b	l1	f1	Dmin	
95°	08	I130.25.250.08.1	S25S DWLNR 08	25	23	23	250	17	32	WNMG 0804
		I130.32.300.08.1	S32T DWLNR 08	32	30	30	300	22	40	WNMG 0804
		I130.40.350.08.1	S40U DWLNR 08	40	37	37	350	27	50	WNMG 0804
		I130.50.420.08.1	S50V DWLNR 08	50	47	47	420	37	63	WNMG 0804
95°	08	I130.25.250.08.2	S25S DWLNL 08	25	23	23	250	17	32	WNMG 0804
		I130.32.300.08.2	S32T DWLNL 08	32	30	30	300	22	40	WNMG 0804
		I130.40.350.08.2	S40U DWLNL 08	40	37	37	350	27	50	WNMG 0804
		I130.50.420.08.2	S50V DWLNL 08	50	47	47	420	37	63	WNMG 0804

Spare parts, parts included in delivery

Designation	Clamp	Clamping screw	Wrench	Spring
..25	A108.102	A105.102 (M5)	A109.107(3 HK)	A113.102
..32	A108.102	A105.102 (M6)	A109.107(4 HK)	A113.102
..40	A108.102	A105.102 (M6)	A109.107(4 HK)	A113.102
..50	A108.102	A105.102 (M6)	A109.107(4 HK)	A113.102

Please check availability in current price and stock list