

# Turning toolholders internal

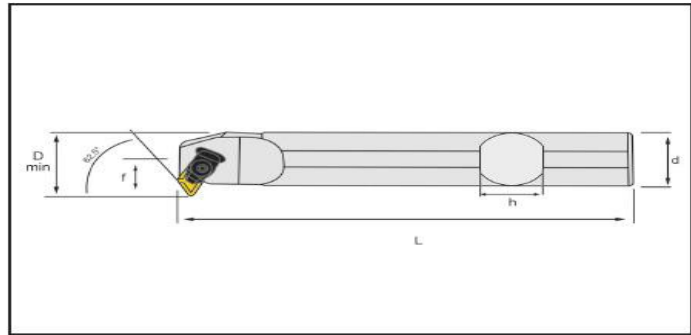
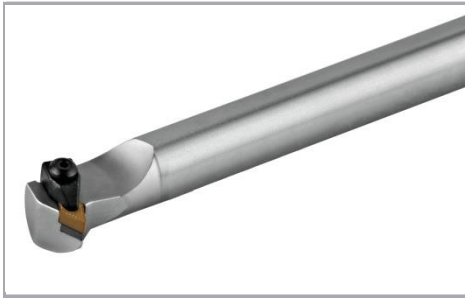

Unit mm

Application	Insert	Order code	Part code	Dimensions						Master insert
				dm	h	b	l1	f1	Dmin	
<b>62.5</b>	<b>15</b>	<b>I123.25.250.15.1</b>	S25S DD-NR 15	25	23	23	250	17	32	DNMG 1506
		<b>I123.32.300.15.1</b>	S32T DD-NR 15	32	30	30	300	22	40	DNMG 1506
		<b>I123.40.350.15.1</b>	S40- DD-NR 15	40	37	37	350	27	50	DNMG 1506
		<b>I123.50.420.15.1</b>	S50V DD-NR 15	50	47	47	420	37	63	DNMG 1506
<b>62.5°</b>	<b>15</b>	<b>I123.25.250.15.2</b>	S25S DD-NL 15	25	23	23	250	17	32	DNMG 1506
		<b>I123.32.300.15.2</b>	S32T DD-NL 15	32	30	30	300	22	40	DNMG 1506
		<b>I123.40.350.15.2</b>	S40- DD-NL 15	40	37	37	350	27	50	DNMG 1506
		<b>I123.50.420.15.2</b>	S50V DD-NL 15	50	47	47	420	37	63	DNMG 1506

Spare parts, parts included in delivery

Designation	Clamp	Clamping screw	Wrench	Spring
..25	A108.102	A105.102 (M6)	A109.107(4 HK)	A113.102
..32	A108.102	A105.102 (M6)	A109.107(4 HK)	A113.102
..40	A108.102	A105.102 (M6)	A109.107(4 HK)	A113.102
..50	A108.102	A105.102 (M6)	A109.107(4 HK)	A113.102

Please check availability in current price and stock list