

Turning toolholders external

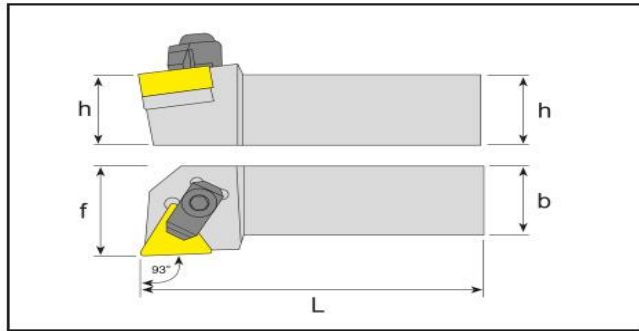

Right hand shown

Unit mm



Application	Insert	Dimensions						Master insert	
		Order code	Part code	h	b	l1	f1		
93°	16	J135.20.20.125.16.1	CTGPR 2020 K16	20	20	125	25	TPK.. 1603	
		J135.25.25.150.16.1	CTGPR 2525 M16	25	25	150	32	TPK.. 1603	
	22	J135.25.25.150.22.1	CTGPR 2525 M22	25	25	150	32	TPK. 2204	
	93°	16	J135.20.20.125.16.2	CTGPL 2020 K16	20	20	125	25	TPK.. 1603
			J135.25.25.150.16.2	CTGPL 2525 M16	25	25	150	32	TPK.. 1603
22		J135.25.25.150.22.2	CTGPL 2525 M22	25	25	150	32	TPK. 2204	

Spare parts, parts included in delivery

For Insert	Clamp	Clamping screw	Wrench	Shim	Shim screw	Spring
TPK.. 1603	CD101.02	CS102 (M6)	W101.1 (3 HK)	STP.16	SS101 (M5)	Y101
TPK.. 2204	CD101.03	CS102 (M6)	W101.2 (3 HK)	STP.16	SS101 (M5)	Y101

Please check availability in current price and stock list