

Turning toolholders external

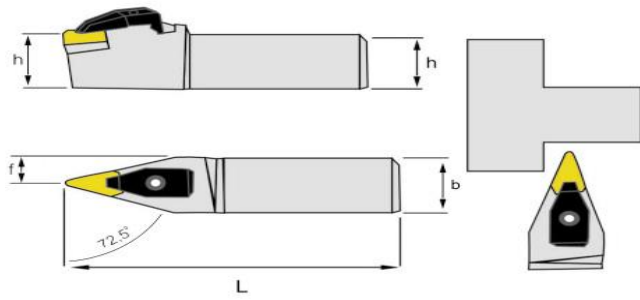

Right hand shown

Unit mm



		Dimensions						
Application	Insert	Order code	Part code	h	b	l1	f1	Master insert
72.5°	16	J123.20.20.125.16.1	DVNNN 2020 K16	20	20	125	25	VNMG 1604
		J123.25.25.150.16.1	DVNNN 2525 M16	25	25	150	32	VNMG 1604
		J123.32.32.170.16.1	DVNNN 3232 P16	32	32	170	40	VNMG 1604

Spare parts, parts included in delivery

For Insert	Clamp	Clamping screw	Wrench	Shim	Shim screw	Spring
VNMG 16..	CD101.03	CS102 (M6)	W101.1 (3 HK)	SVN.16	SS101 (M5)	Y101

Please check availability in current price and stock list